



Final Design Specification for SFSI Test Structure

Design Criteria

- Simple, spread footing at grade
- Minimal compaction of the native soil
- 700-1000 psf footing load to insure high soil stresses
- ~50% of mass in foundation to insure significant SFSI
- Superstructure size appropriate for NEES shake tables (4mx4m, 50 ton maxima)
- Steel moment frame to allow flexibility
- Configurable bracing system to allow stiffness/damping modification
- Strong RC rigid roof slab to allow mass addition and shaker mounting
- 7-10 Hz fixed-base natural frequency of superstructure (can be adjusted from ~5-15Hz with stiffness & mass)

Finite Element Model (SAP2000)

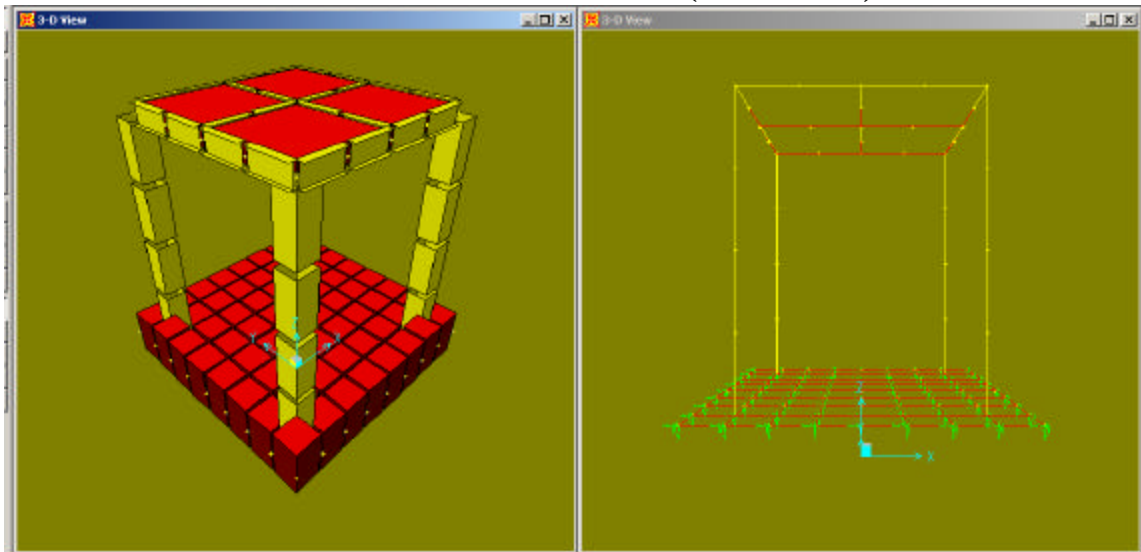

Figure1. Finite element model used for structural design

Materials

- Tube Section
 - Steel, 36ksi
 - TS14x14x5/8 ($A=209\text{cm}^2$, $I=39625\text{cm}^4$) or section with equivalent stiffness & mass

- Height = 3.60m
- Concrete
 - 3000 psi concrete
 - reinforcing as needed for dynamic loads

Roof Detailing

The roof of the structure should satisfy the below requirements:

- Capable of bearing at least 10 tons of uniformly-distributed mass on top
- 40 cm poured concrete thickness
- Rigid connection at joints
- Relatively rigid diaphragm that would move rigidly under dynamic loads from a roof-mounted shaker or earthquakes.
- Can be metal deck, or reinforced concrete, or any suitable composite system.

Total Estimated weight (Kgf)

SECTION	TOTAL
LABEL	WEIGHT
FOUNDATION	19220.92
ROOF(slab)	15136.48
Roof(steel)	801.302
TS14X14X5/8(Column)	2456.149
OTHER	500.00
Total	38114.85

Frequency Analysis result

Stick model

	Fixed base	SFSI analysis
1st frequency	8.4 Hz	5.56 Hz
2nd frequency	N/A	5.56 Hz
3rd frequency	N/A	11.15 Hz
4th frequency	N/A	18.18Hz

LRFD Analysis Envelope Result

Maximum Element Forces				
	Moment		Shear	Axial
	Bottom	Top		
	Columns	853152 Kgf.cm	806662 Kgf.cm	4153 Kgf

Maximum Forces				
	Moment		Shear	Membrane
	Positive	Negative		
	Foundation	8424 kgf.cm	8058 Kgf.cm	116 Kgf

Test Structure Conceptual Design

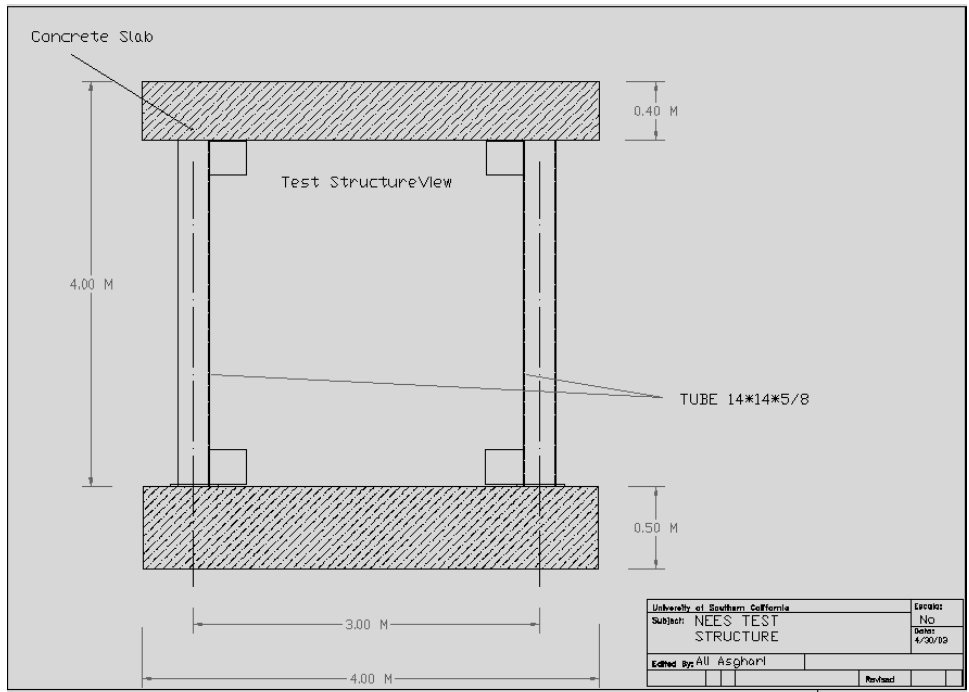

Figure 2. The test structure schematic design, elevation view (symmetric)

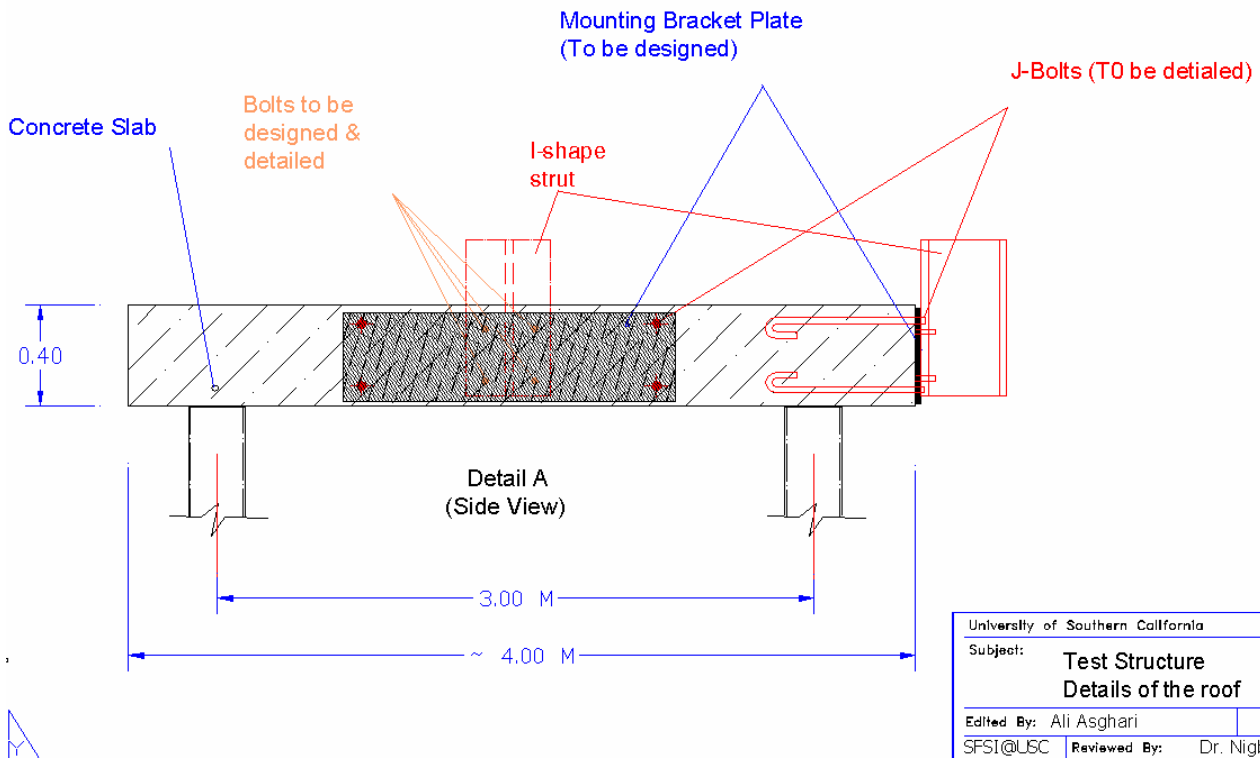

Figure 3. Roof details

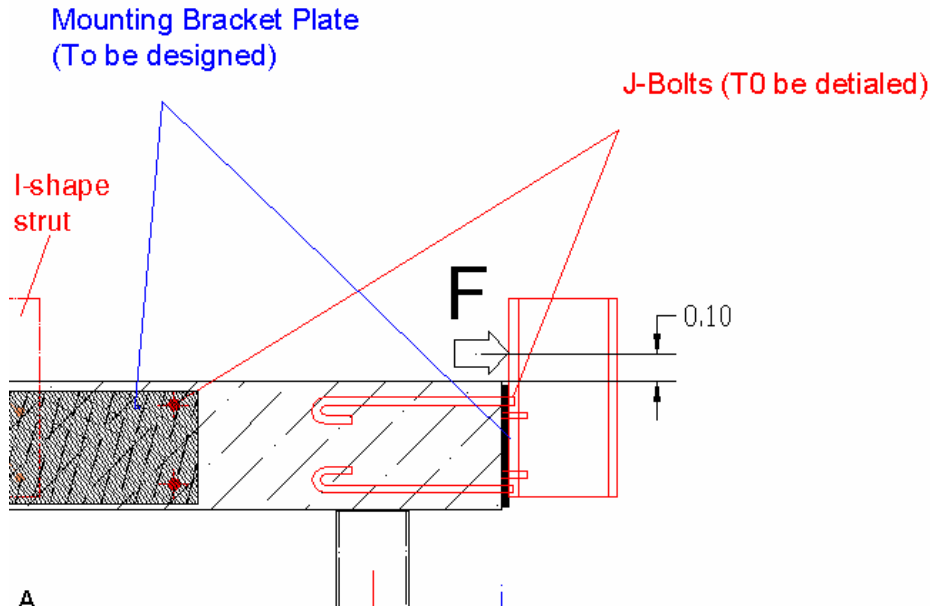

Figure 4. Reaction of UCLA linear shaker force applied to the roof

As depicted in Figure 4, the reaction force induced by the UCLA linear shaker is meant to horizontally shake the structure in either of the two principal axes of the roof slab. The maximum design force is **F=15 Kips** and is applied at distance of 10cm off the roof.

The plates on both sides (east and north) are to be designed and detailed as well as 4 x J-Bolts which retain the mounting bracket plate as base plate for the I shape strut.

Other Considerations

- 1- The finishing of the columns and detailing of the top slab should allow future addition of second story to the structure;
- 2- Bracing Plates should be appropriately implemented to allow X bracing to be added to the structure in order to modify the stiffness in one or both directions;
- 3- The roof and foundation slabs should be 4mx4m in plan, and the columns should be 3m apart measuring between principal axes.